

THE MATCHBOX HD™

IHF<>PRO STEREO INTERFACE AMPLIFIER

HENRY ENGINEERING

503 Key Vista Drive
Sierra Madre, CA 91024
Tel: 626.355.3656
Fax: 626.355.0077
www.henryeng.com

DESCRIPTION

THE MATCHBOX HD is an active interface amplifier that properly interfaces unbalanced "consumer" IHF-standard or Semi-Professional audio equipment with professional studio gear. THE MATCHBOX HD is a bi-directional unit, with four independent amplifiers providing stereo input and output audio interface. Two amplifiers convert a stereo HI-Z unbalanced source to LO-Z balanced outputs at studio level. A second pair of amplifiers converts a stereo balanced studio line source to unbalanced compatible outputs. All four output levels are adjustable. The special "HI GAIN" mode increases the system gain to accommodate exceptionally low unbalanced levels. All circuitry is active and direct-coupled for absolute sonic transparency, making THE MATCHBOX HD ideal for use with digital audio sources such as DAT recorders and computer-based digital sound editing systems.

INSTALLATION

1. Connect the UNBALANCED inputs of the Matchbox to the outputs of an unbalanced device, e.g., the "line outputs" of a DAT recorder.
2. Connect the UNBALANCED outputs of the Matchbox to the inputs of an unbalanced device, e.g., the "line inputs" of a DAT recorder.
3. Connect the BALANCED inputs of the Matchbox to the outputs of a balanced signal source, e.g., the line-level outputs of a professional audio console. NOTE: If the source feeding the Matchbox is unbalanced, install a jumper between pins 1 & 3 on the male XLR plug.
4. Connect the BALANCED outputs of the Matchbox to the inputs of balanced studio equipment, e.g., the line-level inputs of a professional audio console. NOTE: If the Matchbox is used to feed an unbalanced load, connect to pins 1 (Gnd) and 2 (HI) only! DO NOT short pin 3 to ground.

All XLR connectors should be wired as follows: Pin 1=Gnd Pin 2=HI Pin 3=LO
All audio grounds are isolated from the AC ground, which is connected to the Matchbox chassis.

The Matchbox is shipped with all level controls set so that unbalanced input/output levels of -10dBv will produce balanced input/output levels of +4dBu. If other output levels are required, the Matchbox gains may be readjusted via the OUTPUT ADJ controls on the front panel. Use a small screwdriver to carefully adjust the trimpots.

HI GAIN MODE: Some unbalanced equipment, such as computer-based digital audio editing systems, use unbalanced audio levels that are lower than IHF standard. In this case, the HI GAIN mode should be used. Remove the Matchbox cover, and locate JP1 and JP2, near the right side of the PC board. Move JP1 and JP2 to their HI GAIN positions. This will increase the unbalanced input gain by 6dB. It may also be necessary to reduce the unbalanced OUTPUT levels (on front panel) to prevent overdriving the audio inputs of the device being used.

SPECIFICATIONS

UNBAL input to BAL output

BAL input to UNBAL output

INPUT LEVEL	-10dBv nom (HI GAIN: -20dBv)	0dBu to +8dBu nominal
INPUT IMPED	10K ohms (HI GAIN: 5K ohms)	20K ohms
GAIN	+6 to +20dB (HI GAIN: add 6dB)	-6dB to infinity (off)
OUTPUT LEVEL	0 to +8dBu nom, +26dBu max	-10dBv nom, +20dBv max
OUTPUT LOAD	600 ohms or higher, balanced	2K ohms or higher, unbalanced
FREQ RESPONSE	DC to 20 kHz, +/- 0.25dB	DC to 20 kHz, +/- 0.25dB
NOISE LEVEL	-100dBu, 20 kHz b/w	-90dBv, 20 kHz b/w
DYNAMIC RANGE	122dB, 20 kHz b/w	120dB, 20 kHz b/w
DISTORTION	.008% at any frequency	.008% at any frequency
POWER INPUT	115/230 VAC, 50/60Hz, 3 W	
PHYSICAL DIMEN	5.70"w X 1.65"h X 5.60"d; 2.5 lbs	

Specifications subject to change without notice.

Rev. 10/03

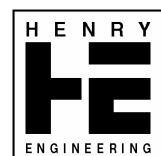

LEFT CHANNEL

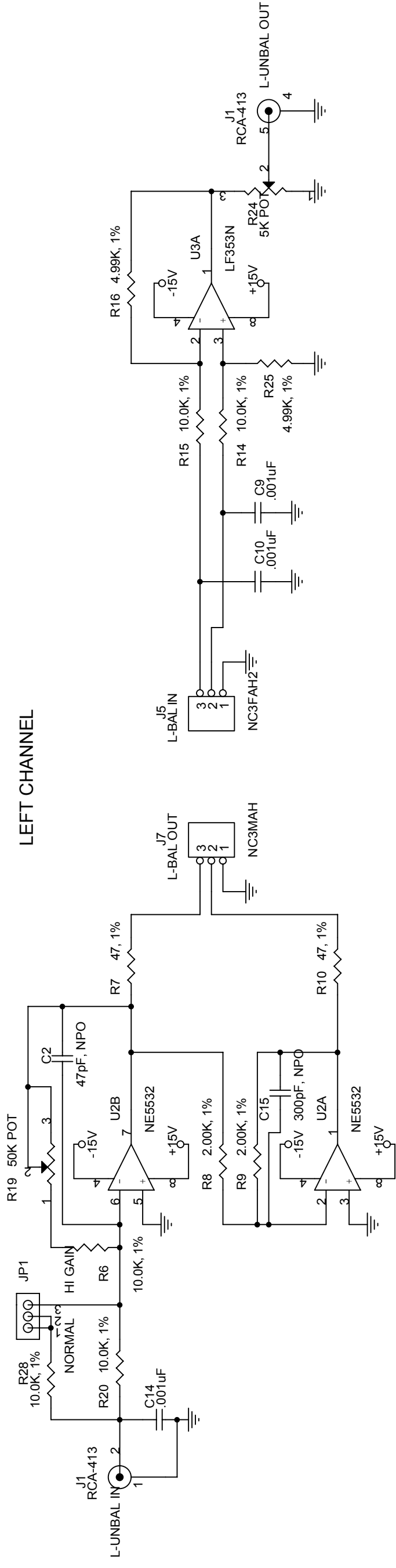

RIGHT CHANNEL

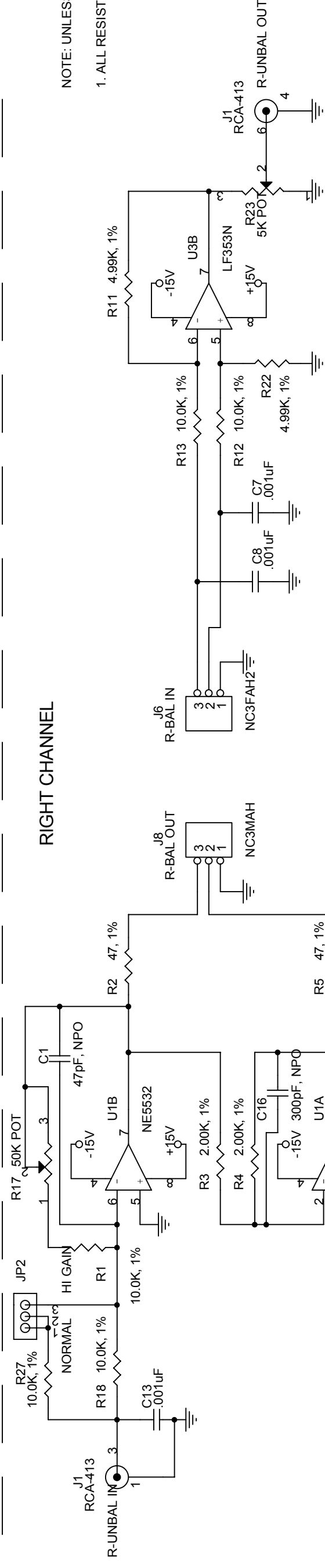

NOTE: UNLESS OTHERWISE SPECIFIED
1. ALL RESISTORS ARE 1/4W, 1%.

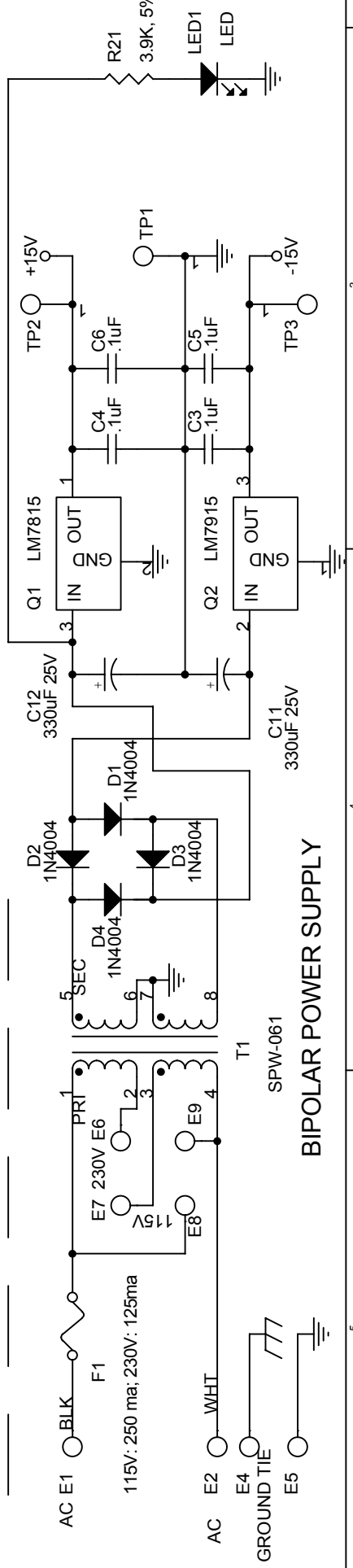

BIPOLAR POWER SUPPLY

HENRY ENGINEERING
503 Key Vista Drive
Sierra Madre, CA 91024 USA
Telephone - (626) 355-3656
FAX (626) 355-0077

Title	SCHEMATIC: MATCH BOX II		
Size	B	Document Number	3110
Rev	B	Date:	Monday, September 29, 2003 Sheet 1 of 1